

M05 Dimesions			
Code	Width	CTC	THRU FIXING HOLE SIZE
M05.25.200	25	200	8
M05.25.300	25	300	8
M05.25.400	25	400	8
M05.25.600	25	600	8
M05.40.200	40	200	8
M05.40.300	40	300	8
M05.40.400	40	400	8
M05.40.600	40	600	8

	Drawing M05 Drawing
	Date 8/09/2023
	Scale 1:2

Grub Screw

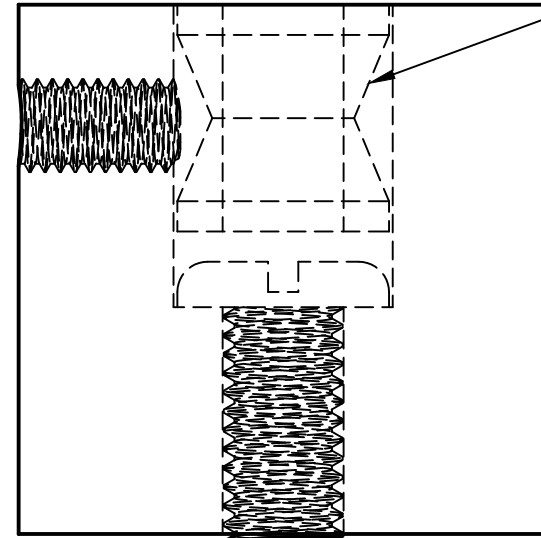
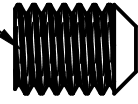

Brass Ferrule

Handle Stand

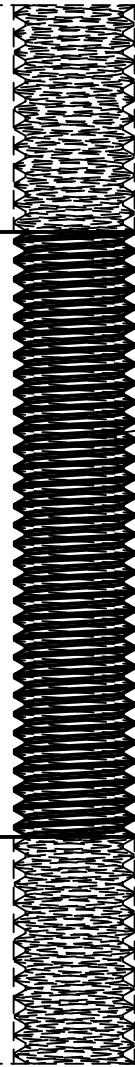

M8 Bolt

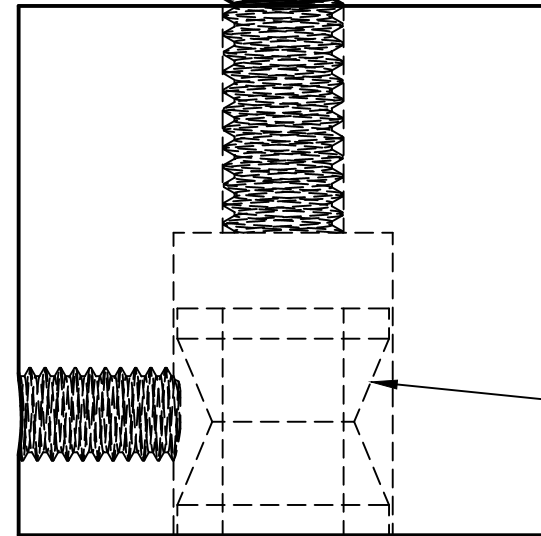

Threaded Handle Stand

Brass Ferrule

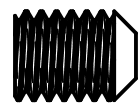

Installation Instructions

IMPORTANT! Mark and drill door from both sides.

Cut bolt to required length. Allow 30mm longer than door thickness.

Screw stands together through door.

Place handle on stand, inserting Ferrules into stand.

Tighten Grub Screws



Drawing
Entrance Handle Fixing B2B

Date
2/02/2023

Scale
2:1

Installation Instructions
IMPORTANT! Mark and drill door from both sides.
Cut bolt to required length. Allow 15mm longer than door thickness.
Screw stands from behind to door.
Place handle on stand, inserting Ferrules into stand.
Tighten Grub Screws

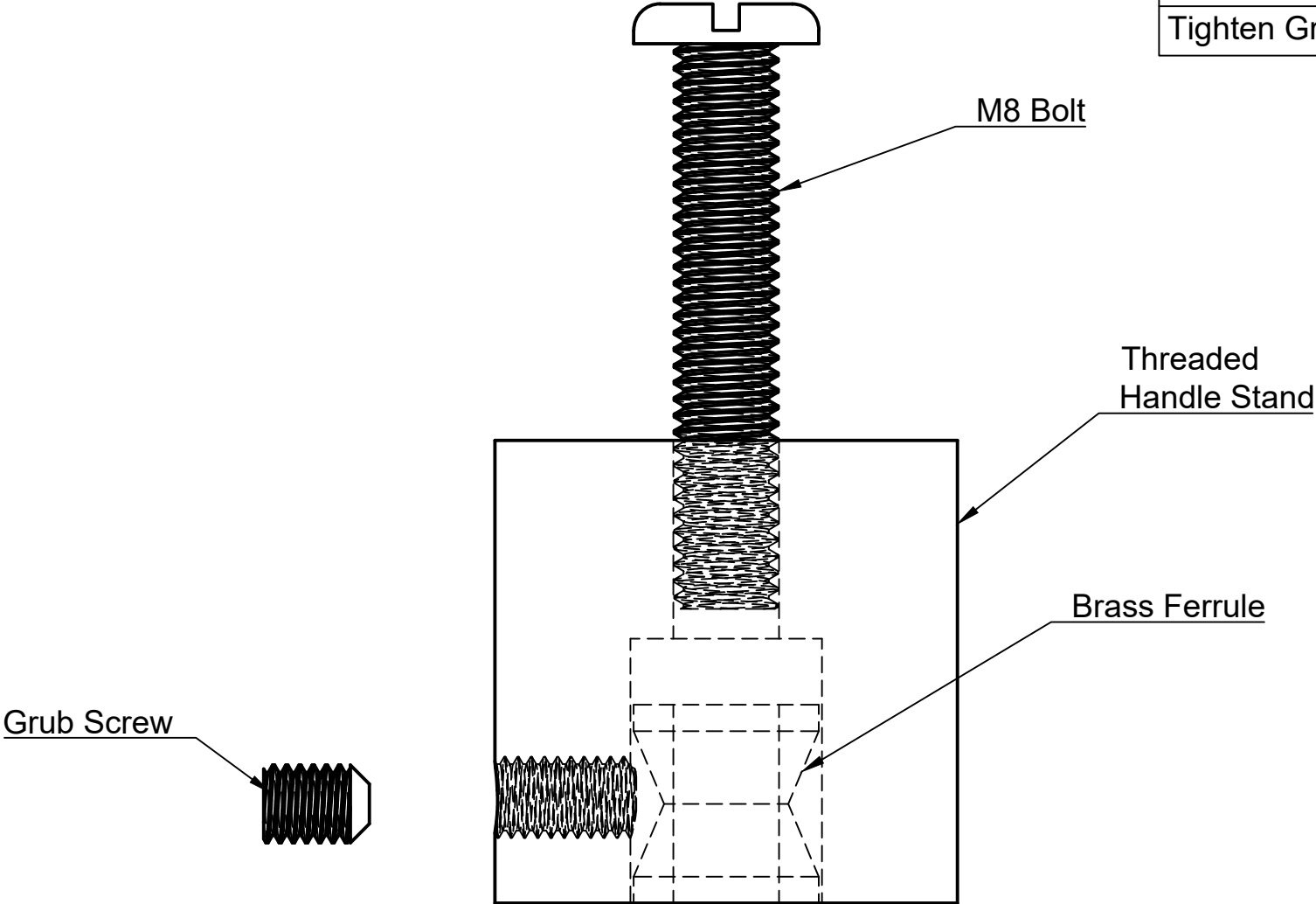

Drawing
Entrance Handle Rear Fixing
Date
2/02/2023
Scale
2:1

Installation Instructions

Screw stand to door.

Place handle on stand, inserting Ferrules into stand.

Tighten Grub Screws

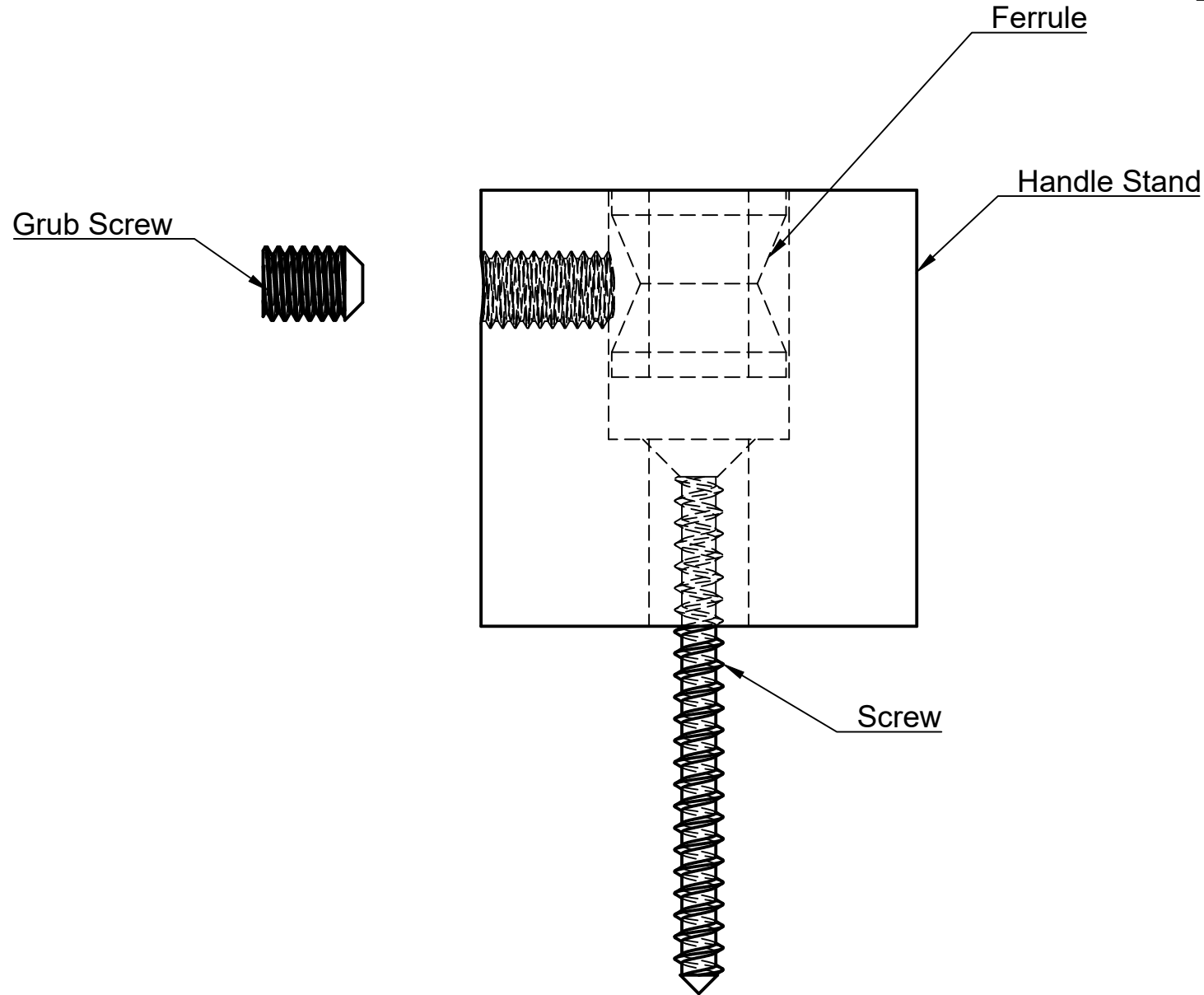

Drawing
Entrance Handle Surface Fixing

Date
2/02/2023

Scale
2:1